

Product Information Bulletin 243

Measures to Control Pest Infestation



Product Information Bulletin

BULLETIN NO.	243
ISSUED:	July 14, 2005
REPLACES:	June 15, 2005

Measures to Control Pest Infestation

This bulletin provides general recommendations on good building practices that builders and home owners can follow in areas where infestation by pests like carpenter ants and termites is possible. Preventing pest infestation in any structure is easier than curing it and prevention is easier to incorporate during construction. Local building codes should be referenced for information on locations where pest infestation may be a concern.

Building code design requirements that can protect against decay and pest infestation such as using pressure treated lumber for the sill and other areas subject to dampness must always be followed. The following summarizes some recommended good building practices that will reduce the opportunity for pest infestation.

1. Remove all stumps, roots and wood debris from the immediate area around the house. Leave a buffer zone of approximately 30 m (100 ft) between the house and surrounding vegetation, and protect against "aerial attack" by trimming back any overhanging tree limbs. Seal and periodically check all potential entry points.
2. Clear away any natural nesting materials such as dead trees and downed limbs, and store firewood well away from the house.
3. In areas that are particularly prone to pest problems such as heavily wooded areas or low shaded areas where the ground stays damp, consider utilizing baiting systems and/or perimeter soil and foundation treatments using a long-acting pesticide prior to backfilling.
4. Ensure that the landscaping around the foundation is sloped to provide adequate drainage of free water away from the foundation.
5. The finished grade should provide approximately 300 mm (12") clearance to the underside of the base plate or framing and 150 mm (6") to siding.
6. In termite prone areas, consider treating the soil around the house after backfilling and installing a termite shield under the sill.
7. Another good and effective practice against both carpenter ants and termites is the treatment of the wood parts of the house with borate-based compounds during the construction of the building. Borate compounds are generally considered to be non-toxic to humans and easy and effective to apply.

The attached building performance bulletin published by the Canadian Wood Council entitled: **Termite Control and Wood-Frame Buildings** is a reference source that provides additional information on measures to control infestations. The bulletin details an *integrated pest management* strategy that employs a combination of control measures.

For additional information applicable to specific building locations, builders and homeowners should always consult a local treatment expert for recommendations on long-term pest control methods.



Termite Control and Wood-Frame Buildings

Building Performance Series: No. 3

Information Sources

Web Sites

Wood Durability Web Site
www.durable-wood.com

National Pest Management Association
www.pestworld.org

Treated Wood Associations

American Wood-Preservers' Association
PO Box 5690
Granbury, TX 76049-0690
[817] 326-6300
[817] 326-6306 (fax)
www.awpa.com

American Wood Preservers Institute
2750 Prosperity Avenue, Suite 550
Fairfax, VA 22031-4312
[703] 204-0500
[703] 204-4610 (fax)
www.awpi.org
www.preservedwood.com

Canadian Institute of Treated Wood
2141 Thurston Drive, Suite 202
Ottawa, ON K1G 6C9
[613] 737-4337
[613] 247-0540 (fax)
www.citw.org

Research Organisations

Forest Products Laboratory
U.S. Department of Agriculture Forest Service
One Gifford Pinchot Drive
Madison, WI 53705-2398
[608] 231-9200
[608] 231-9592 (fax)
www.fpl.fs.fed.us

Forintek Canada Corp.
2665 East Mall
University of British Columbia
Vancouver BC V6T 1W5
[604] 224-3221
[604] 222-5690 (fax)
www.forintek.ca

Louisiana State University
LSU Agricultural Center
PO Box 25203
Baton Rouge, LA 70894-5203
[225] 578-4161
[225] 578-4143 (fax)
www.agctr.lsu.edu/termites/

University of Toronto
Faculty of Forestry
33 Willcocks Street
Toronto, ON, Canada M5S 3B3
[416] 978-5755
[416] 978-3834 (fax)
www.utoronto.ca/forest/termite/termite.htm

Building Performance Bulletin



1. Introduction

Wood products have long been the building materials of choice for home construction in North America. The wood-frame construction system has a solid history of producing housing of the highest standards: It is easy to build, delivers economic value, has excellent strength in earthquake or high-wind conditions, is energy efficient, and is derived from a renewable resource.

Modern wood-frame construction includes several types of engineered wood products that are economically viable in multi-story residential buildings and non-residential projects. Moreover, as described in Bulletins No. 1 and 2 in the Building Performance Series, wood framing supplies durability and fire safety performance where environmental and building code requirements are met.

This bulletin describes how wood framing can also be used in areas of North America subject to insect attack, a threat to all types of buildings. It builds on the concept of *integrated pest management* that will provide long-term protection for wood-frame and other buildings against damage caused by insects, specifically Formosan and other subterranean termites.

Also included is practical advice for building designers, contractors and owners to assist in assessing risk, and choosing appropriate mitigation measures.

Integrated pest management (IPM) is a strategy that combines different pest control measures (see Section 4) and applies these at varying frequencies and degrees depending on the stage of an actual or potential infestation. As conditions change, control measures can be applied to meet the increased or decreased insect hazard, while always maintaining an appropriate level of base protection.

2. Durability and Wood

Prevention of insect damage and decay caused by penetration of moisture are key issues when building with wood. Proper construction detailing to ensure long-term durability of wood-frame buildings in high moisture conditions has been described in Bulletin No.1, *Moisture and Wood-Frame Buildings*, of the Canadian Wood Council Building Performance Series.

Insects – mainly termites, carpenter ants and powder post beetles – can cause significant property damage. However, insect damage need not occur and the information in this bulletin is intended to help prevent this damage.

Insect damage is not restricted to wood-frame structures and one- or two-story developments. In fact, termite colonies, sustained by moisture from rainwater or other sources, have been found as high as the 17th story in concrete buildings in Honolulu and Miami.

Nor is damage entirely restricted to wood or cellulose-based components. Termites chew through cable shields, plastic laminates and foam insulation. In areas where there is an identified risk of termite infestation, it is prudent to take precautionary measures, whatever the building size or construction type.

Various types of powder post beetles and carpenter ants are found throughout the U.S. and parts of Canada. These insect pests, however, cause limited damage and are relatively easy to control.

Subterranean termites, those that enter buildings from nests underground, are economically the most significant insect pests in terms of damage. In particular, one non-native species, the *Formosan subterranean termite (FST)* or *Coptotermes Formosanus*, although restricted to the southern U.S., is responsible for a significant portion of all insect damage to buildings in the U.S.

It is now generally recognised that total eradication of these insect pests is not a realistic goal, and that pest control efforts should be focused on containment of existing insect populations, and on the limitation of risk to buildings through the implementation of integrated pest management strategies.

¹Morris, P.I. 2000. *Integrated control of subterranean termites: the Six S Approach*. Proceedings of the American Wood Preserver's Association. 96: 93-106

One such approach, the “6-S” strategy, is described in this guide¹. The 6-S strategy includes:

- Suppression
- Site Management
- Soil Barriers
- Slab and Foundation Details
- Structural Protection
- Surveillance and Remediation

The measures required in any individual situation will depend on the type and number of insects present in the area, and the threat that they represent to a given structure.

In areas where Formosan termites are well established, they pose the most significant threat to buildings, and therefore demand the most comprehensive response. For this reason, Formosan termites are the main focus of this bulletin. Other insect pests can typically be controlled by selecting the most appropriate measures from those listed in Section 4 below.

3. Insects That Damage Wood

Termites

Worker termites can be distinguished from worker ants by their creamy-white color and slower movement. During the flying stages (alates) termites are distinguishable from ants by their thicker bodies, straight antennae, and by the equal size of their front and rear wings (see Figure 1). There are three categories of termites found in North America, differentiated according to their moisture requirements. These are:

- dampwood termites
- drywood termites
- subterranean termites

Dampwood termites are prevalent in the Pacific Northwest and primarily attack decaying wood. Eliminating the moisture source leading to the decay normally controls them. They do not constitute a major risk to a building's integrity.

Drywood termites need no significant moisture source, and may consequently fly into buildings and set up colonies in dry wood, bypassing the physical barriers used against other termites. They are found in the southern tier states of the U.S., Hawaii and Mexico. Drywood termites can be combatted by the use of treated wood components, and eradicated by fumigation or heat treatment (see Section 4.6).

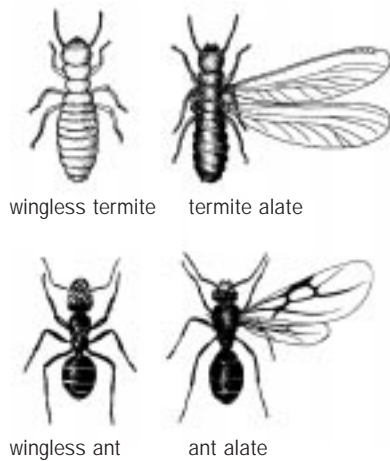

FIGURE 1: Appearance of Termite vs. Ant
 [Courtesy Louisiana State University, Agricultural Center]

Subterranean termites are susceptible to desiccation, and require a reliable source of moisture, usually soil. Although satellite nests may be found in build-



PHOTO 1: Subterranean termites build shelter tubes or mud tubes that serve as “climate controlled” access routes to a building. [Photo: Louisiana State University, Agricultural Center]

ings if there is moisture, the main nest is usually found in wood that is in contact with soil. Subterranean termites build characteristic shelter tubes of mud, wood fibre and saliva, that allow them to pass from the soil into buildings, protected against desiccation and predators. These tubes may cross inert material, such as concrete foundations. Termites can also pass through cracks in concrete as narrow as 1/25”.

Within this group, Formosan termites should be distinguished from native subterranean termites as they can cause severe damage, and much more rapidly than indigenous species. Formosan termites were accidentally introduced to Hawaii and the southeastern U.S. from Southeast Asia at the end of the Second World War. At 1/4” in length, Formosan termites are slightly larger than their native counterparts. Their colonies are also larger, covering up to half an acre, and numbering many millions of insects. Native termites are found throughout the continental U.S., except Alaska, while Formosan termites are restricted mainly to states bordering the Gulf of Mexico and Hawaii.

When a termite colony has grown to a sufficient size, winged alates develop and fly at particular times of the year to establish new colonies. Native subterranean termites tend to make their dispersal flights in warm weather between January and April. Formosan subterranean termites tend to fly later in the year. For example, in New Orleans they fly from May through the end of June. They rarely travel more than 1/4 mile from their nest before descending, pairing and digging into the ground to establish a new colony.

Carpenter Ants and Powder Post Beetles

In contrast to termites, *carpenter ants* do not eat wood and other cellulose-based materials, but instead simply excavate living quarters and hatching chambers that are usually quite limited in extent. Powder post beetles only do significant damage when multiple generations continually re-infest the same piece of wood. Also, powder post beetle damage is restricted to hardwoods, and since most structural framing is made of softwood lumber it is rarely attacked by these insects.

Carpenter ants, found in the Pacific Northwest, the northern Midwest, New England and southern Canada, are distinguishable from termites by their dark colour, narrow waists, elbowed antennae and, when present, the large front and small rear wings. Carpenter ants rarely attack sound dry wood, preferring damp wood, foam or cellulose insulation, and do not use wood for food. They are more easily spotted than termites as they expel wood fragments from their excavations, and forage for food in the open. The presence of carpenter ants may indicate moisture problems in the building as they generally prefer already rotting wood.

Several species of *powder post beetles* are to be found in the U.S. and Canada. They vary in length from 1/16” to 3/8”, but generally have flattened bodies, a prominent head and segmented antennae. True powder post beetles attack only hardwoods (particularly oak, hickory, ash, walnut and cherry) but other species of wood boring beetles attack both hardwoods and softwoods.

Carpenter ants and powder post beetles are much less hazardous than termites and easier to control through common, professionally administered pest-control measures. Therefore, the remainder of this bulletin is devoted to the control of termites.

4. Control Measures – Integrated Pest Management (Termites)

As previously discussed, *integrated pest management* is a strategy that combines different pest control measures. Below is one approach to formalising an integrated pest management strategy using six lines of defence: The Six S Approach. The number of control measures and the intensity of each measure are largely based on an assessment of the costs versus the risks.

4.1 Suppression

Suppression refers to measures intended to reduce and eventually eradicate termites from infested materials in a designated area. The area can be as large as a portion of a state or may be limited to a single house.

Attempts to reduce termite populations over a specific area, or across a portion of a state or province, are useful where termites have been recently introduced, are sporadic in distribution, and primarily spread through man’s activities. Termite populations that might be effectively controlled in this way include Formosan termites in pockets of the southeastern U.S., and eastern subterranean termites in southern Ontario, Canada.

If done on a regional or state-wide basis, baiting (see Section 4.6 Surveillance and Remediation) and trap-treat-release methods may also constitute an effective method of suppression. Area-wide suppression is obviously beyond the means of the builder or homeowner as it requires a concerted effort and co-

ordination of various levels of government. However, in some areas baiting is commercially available to homeowners and can be an effective alternative to chemical soil treatment.

Suppression methods include systematic location and destruction of colonies not associated with buildings (such as in street trees), systematic inspection of wood products leaving an infested area to quarantine the infestation, burning of infested lumber, and heat treatment of reclaimed lumber.



PHOTO 2: Trees containing termite nests can be injected with termiticide to reduce termite populations in designated areas. [Photo: Louisiana State University, Agricultural Center]

4.2 Site Management

Careful site preparation and clean-up can do much to discourage the colonisation of a new or existing building site by termites. Where forest or orchard land has been cleared, tree roots must be completely excavated and removed along with any other buried wood.

During construction, it is important that:

- stumps be removed
- all wood and other cellulose containing construction debris be removed from the site
- survey pegs and concrete formwork be removed and disposed of properly, rather than buried or encased in concrete
- excavation spoil is not used to fill in under porches or steps
- site grading drains water away from the building
- non-treated wood elements be raised from the ground according to the following table:

TABLE 1: Height above ground of non-treated wood elements.

Non-Treated Wood Element	Minimum Height Above Ground Permitted (inches) ¹
Floor joists	18
Studs	8
Wood veneer	6
Girders	12
Posts in crawl spaces	8
Columns	6
Columns above concrete	1

¹ Based on the U.S. model building codes and American Forest & Paper Association recommendations.

For landscape management of existing sites, it is important that:

- there be no wood-to-soil contact for untreated wood, including things like wood piles, sheds or patios – these should be raised from the ground onto patio stones or blocks
- all posts be mounted on metal brackets or concrete post supports

4.3 Soil or Chemical Barriers

In the past, primary protection of buildings from termite infestation has been by the application of highly toxic and persistent chemicals, generally chlorinated organic compounds. When applied properly, and not breached or bridged, such barriers could exclude termites for up to 50 years. Recently, in the face of growing concern over potential environmental impacts and health risks, many such chemicals including the chlorinated cyclodienes such as chlordane and the organophosphates such as chlorpyrifos have been withdrawn from the market. They have been replaced by less persistent chemicals such as pyrethroids, which have shorter effective lives, typically about 5 years. These chemicals should not be used on sites with wells or other ground sources of water supply. Also, there may be difficulty in reapplying the treatment, particularly if the building has a slab on grade.

Recently, a new generation of physical barriers promises longer effective life without negative environmental impacts. These barriers consist of either a 4" thick layer of precisely sized sand or crushed stone beneath slab foundations, or inside the footer and along the outside of the stem wall of crawl-space foundations. The sand particles are too heavy for the termites to move, and the spacing between them too small for the termites to squeeze through. The most effective particle size has been found to be between 1/16" and 1/10" in diameter, but varies according to the termite species in question. In Hawaii, where they were first developed, sand barriers are referred to as basaltic termite barriers (BTBs).

The installation and maintenance of sand barriers requires attention to detail:

- the material must be properly tamped, and left undisturbed by anyone working around the foundations
- detailing must ensure that water drains away from the foundations
- mulch, topsoil, etc. must be kept away from the building and not allowed to bridge across or bypass soil barriers
- trees should be planted far enough away so that branches and roots do not reach the building

FIGURE 2: Caps and Pads –
A Building Tip for Pier Construction

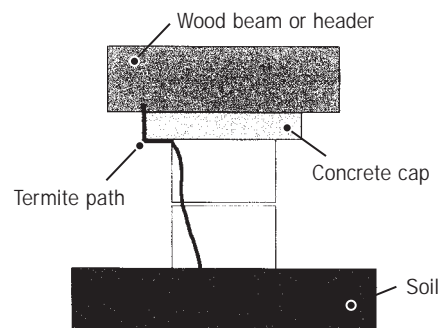

Brick and hollow block piers can be made more termite resistant through the use of solid concrete caps. Caps force termites tunneling within the hollow blocks to move to the exterior of the cap where they can be detected.

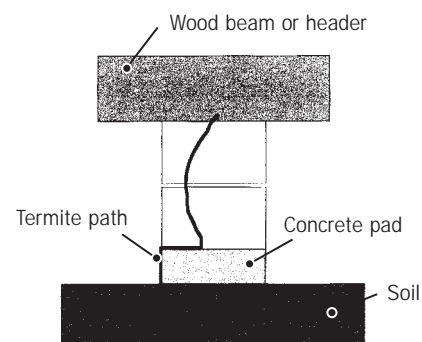

Solid concrete pads also force termites to build exterior mud tubes for easy detection. Pads are easiest to treat since only the soil around the perimeter needs treatment, not the interior of the pier. The pad should have no cracks and extend above the soil.

[Courtesy Louisiana State University, Agricultural Center]

4.4 Slab and Foundation Details



PHOTO 3: Termite mesh, a more recent development, is used to wrap the perimeter of the foundation or to prevent termites from gaining access through service penetrations. [Photo: Termi-Mesh Florida LLC]

Foundation walls and slabs should be designed to inhibit the entry of termites into the building, and to facilitate inspection for shelter tubes. Monolithic slabs should be designed so that shrinkage cracks do not exceed 1/25" in width. Control joints in non-monolithic slabs should be similarly designed. Any openings cut for pipes and other penetrations should be sealed with non-shrinking grout, and the sides of foundation walls or slabs should be exposed for a minimum 6" above finished landscape grade. Crawl spaces should be a minimum of 18" clear height and fitted with access hatches. If hollow masonry units are used for foundation walls, they must be capped with concrete and protected by an effective chemical soil barrier.

Sheet metal barriers can be installed between the top of the foundation and the sill plate, with the outer edge projecting from the exterior of the building at 45 degrees, like a conventional flashing. Soldering the joints creates a continuous barrier. To enter the building, termites must tube out and around the metal projection, making detection of their presence considerably easier. Sheet metal barriers, if properly constructed and regularly inspected can be a highly effective means of excluding termites in structures with crawl-space or basement type construction. However, if a basement is finished, the barrier is obstructed from view and the termites may use basement framing to gain access to the structure.

A more recent development is termite mesh. Mesh is used to wrap the perimeter of the foundation to protect at-grade or below-grade penetrations of foundations and slabs. Mesh should have a grid spacing of

1/32-in. to exclude even the smallest termites. Clamps are used to secure mesh to all pipes and other penetrations of the slab, and are parged onto the foundations with a cementitious compound.

Marine grade stainless steel mesh, with an estimated 20-year service life, is installed by licensed contractors. The steel grade resists corrosion, but can add to costs, that vary considerably according to the complexity of the foundation design. During construction, it is vital that all sub-trades respect the integrity of the termite mesh throughout the construction process.

4.5 Structural Protection – Preservative Treatment

For many years, preservative treated framing has been used in parts of buildings in termite areas. Building codes vary in requirements – some specify that timber elements 18 inches or less from the ground be treated, others may require that other specific elements be treated. Preservatives, including CCA, have a 60-year history of deterring termites from attacking framing. However, the search is always on for new types of preservatives.

In April 2000, several wood preservative producers jointly launched a range of wood products treated with borate (B_2O_3), a water-soluble chemical that kills insects that feed on it, while being considered benign in contact with humans. In its various forms borates already appear in a range of common domestic products from eye-drops to washing powder.



PHOTO 4,5 and 6: Termite shields, or sheet metal barriers, are installed between the top of the foundation and the sill plate. By projecting out and down at a 45 degree angle, the barriers force termites to tube around them for easier detection. [Photos: Tim Myles, University of Toronto]

Products such as zinc borate treated oriented strand board (OSB) sheathing, cellulose insulation, and sodium borate-treated dimension lumber are becoming available, making it more feasible to construct a house in which many primary and secondary structural components are termite resistant. It is believed that the water soluble borate treatment can actually migrate towards the moisture generated by termites in the tubes, and in doing so, repelling or killing the insects. Borate-treated wood is not recommended for use in the outdoors without a three-coat finish, e.g., for decks, due to water solubility. It is very suitable for use as framing lumber in structures.

Preservative treatment specifications for most wood products are tabulated in the American Wood Preserver's Association (AWPA) standards. AWPA standard C31 covers preservative treatment with borates for interior-dry and interior damp conditions (protected from liquid water). Two levels of treatment are provided: a lower loading for decay and native North American termites and a higher loading for decay and Formosan termites. AWPA standard C2 covers preservative treatment with CCA and other leaching-resistant preservatives for interior-damp, exterior-above-ground and exterior-ground-contact applications. Again, two loadings are specified, but the difference is that the lower loading is for above-ground applications (interior or exterior) and the higher one is for ground-contact applications. None of the preservatives listed in AWPA C2 require higher loadings for Formosan termites. Hem-Fir North and Coastal Douglas Fir are listed in AWPA C31. Western Spruce-Pine-Fir, Hem-Fir-North and Coastal Douglas Fir are listed in AWPA C2.

The introduction of the Use Category System in the AWPA standards in 2000 greatly simplifies the process of selecting specifications for preservative-treated products. Specifiers look up a wood product in a list that indicates which Use Category it falls into. They then can look up their preferred wood species and preservative in the table for the Use Category to determine what preservative loading is required. Alternatively they can simply specify wood treated to one of the five major Use Categories (UC1-UC5 with sub categories) with the confidence that it will provide an acceptable performance in the intended end use.

As with cement dust and other building materials, treated wood requires some care in handling during construction. Builders and do-it-yourself enthusiasts



PHOTO 7: Protecting the structure by building with borate-treated wood products is a suppression option in certain situations. [Photo: Louisiana-Pacific® SmartGUARD™]

should refer to Consumer Information Sheets for the appropriate health and safety precautions in using preservative treated wood. Borate-treated wood should be transported and stored under cover prior to construction and should be closed in as soon as practicable. Short-term exposure to rain during construction is not a problem.

Some wood species are naturally resistant to termites and can be used for interior finishes and fixtures. Where appropriate, these species can also be used for structural members offering an alternative to treated wood. Redwood, cypress, western red cedar, yellow cedar, and Alaska yellow cedar are some of the native species that are resistant to termites. Of these, yellow cedar is considered the most resistant.

4.6 Surveillance and Remediation

Regular inspections are necessary in identifying any problems while they are still manageable, and the identification and eradication of termite colonies that are in proximity to buildings, is fundamental in reducing risk. As part of this surveillance, it may be appropriate to use specific remediation measures to prevent recurrence of the problem. In recent years, the general application of toxic chemicals to eradicate termites as a remediation measure has been replaced by more focused approaches, such as baiting, that are less hazardous to the environment.

Remediation 1: Baiting

Baiting involves placing bait tubes or traps in the ground at intervals around a building – several dozen for a typical house. Pieces of untreated timber or other cellulose-based material are inserted into these tubes as bait for termites. The tubes are monitored and, when termites are observed feeding on the bait, it is replaced with a treated bait containing a chemical that the termites then carry back to the colony. The



PHOTO 8: A bait assembly being installed beneath a patio. Baits contain slow-acting termiticide that termites carry back to infest the entire colony. [Photo: Louisiana State University, Agricultural Center]

chemical is slow acting, so termites are unable to associate its source with its effects. Over a period of several months, the entire colony may be destroyed.

When no further activity is observed in the tubes, the treated bait is removed, and replaced with an untreated bait. Monitoring continues on a regular basis, and the procedure is repeated as necessary.

Several companies offer products and services that are variations on this method of site treatment, although baiting is still a relatively new approach for termites.

Remediation 2: Fumigation or Heat Treatment

The chemical fumigation or heat treatment of a termite-infested building requires the services of a licensed professional contractor. There are two basic approaches to remediation: fumigation, and heat treatment. The chemical compounds used in fumigation are toxic, and generally require evacuation of the building for a period of several days.

To eradicate termites and other wood-boring insects with heat, the core temperature of all wood elements in the building must reach 120°F for a continuous period of 30 minutes. Generally, this will require the ambient air temperature in the building to be raised to 160°F, (the temperature of a sauna), for about one hour. To achieve this, it is necessary to wrap the building in insulating material, and to protect heat-sensitive items such as electronic equipment. Because it is almost impossible to maintain the required temperatures in wood elements that are in direct contact with concrete foundations (because of their “heat sink” effect), this method is most effective against non-subterranean species of termites, carpenter ants and powder post beetles.

It should be noted that while either fumigation or heat treatment will eradicate insects from a building,

they will not prevent reinfestation. Regular inspection and maintenance will do much to reduce the risk of infestation. Look for debris and other food sources and for potential bridges into the building (see Section 4.2 Site Management). Check also for sources of moisture such as:

- leaking downspouts or gutters
- poorly ventilated bathrooms, clothes dryers, etc.
- air-conditioner condensation leaks
- leaking pipes
- leaking seals around windows and doors

5. Assessing Risk and Choosing Appropriate Lines of Defence

Some indication of the area to which Formosan termites might spread can be deduced from the Japanese experience. In Japan, Formosan termites have not crossed the 39° F January average minimum isotherm.

Of the six lines of defence described above, not all will be necessary or appropriate in every situation. In areas of low Formosan termite risk, only two or three lines of defence will be adequate. In areas of high risk, all six lines of defence may be needed. Table 2 lists the lines of defence recommended for various levels of risk.

University based urban entomologists and local pest control professionals are the best source of information, although mapping programs are underway in some areas that will assist designers and builders to make their own assessments. A key factor will be the likelihood of Formosan termites becoming established locally during the life of the building.

In summary, minimising damage caused by Formosan termites should be based on the following principles:

- control methods should be consistent with current and predicted threats of infestation
- control methods should be economically and environmentally feasible to reduce and contain the current termite population
- the public, building owners, designers and the construction community should encourage and adopt methods to prevent infestation

The American Wood Council (AWC) of the American Forest & Paper Association recommends mapping current Formosan termite populations to better determine the geographic areas of low, medium and high risk as a first step in any termite management program.

AWC further recommends that legislated control methods be in the form of performance standards, rather than prescriptive regulations that would impose uniform “blanket” requirements in every case regardless of risk. Performance standards would, instead, permit maximum flexibility for designers and builders to meet a defined level of protection by responding to the demands of each project, and would permit new and innovative control methods to be adopted without recourse to new legislation.

6. Conclusion

Effective control of termites requires several lines of defence which may be selected from the six measures outlined in Section 4. Allowances must be made for the inevitable imperfections in construction and maintenance. However, with the products, technologies and approaches now available, wood frame buildings remain a viable option even in the most termite-prone areas.

Checklist for Staying Termite-free

If you live in a termite-prone area, assess your hazard exposure and use the information here to develop a termite management strategy that includes some or all of the control measures presented. Termite management is an ongoing process that with constant vigilance and maintenance can save a lot of trouble, worry and money.

- have a professional inspection done every year
- keep termite habitats away from the immediate area around the building
- clear or relocate buried wood such as tree stumps, firewood, scrap wood, cardboard boxes and plants
- be vigilant for foundation settling or shifting that could open new paths for termite access
- quickly fix any roof or plumbing leaks so that moisture does not enter the building envelope
- keep roof gutters in good repair and ensure they direct water away from the building
- maintain the integrity of physical barriers such as sand or mesh – do not lay soil or mulch over the barrier, or let roots grow through it
- repair poorly ventilated bathrooms, leaking pipes, clothes dryers and air-conditioner condensation leaks that result in termite-attracting moisture accumulation
- do not store wood, cardboard boxes or other cellulose-based material in crawl spaces

TABLE 2: Termite Control Strategies for Various Degrees of Termite Risk

Line of Defence	Termite Risk			
	High & Formosan	High	Medium	Low
Suppression	✓			
Site management	✓	✓	✓	✓
Soil/chemical barriers	✓	✓	✓	
Slab/foundation details	✓	✓	✓	✓
Structural protection	✓	R ¹		
Surveillance & remediation	✓	✓	✓	✓

¹ Recommended

Canadian
Wood
Council

Conseil
canadien
du bois



Other titles in the Canadian Wood Council
Building Performance Series

- *No.1 Moisture and Wood-Frame Buildings*
- *No.2 Fire Safety in Residential Buildings*

These may be obtained free of charge
by faxing to [613] 747-6264.

Canadian Wood Council

Conseil canadien du bois
1400 Blair Place, Suite 210
Ottawa, ON K1J 9B8
Tel: 1-800-463-5091
Fax: [613] 747-6264
e-mail: info@cwcc.ca

Our Web Sites:

Canadian Wood Council:
www.cwc.ca

Canada's Forest Network:
www.cfn.ca

Wood Design & Building Magazine:
www.wood.ca

WoodWorks® Design Office Software:
www.woodworks-software.com

WoodWORKS! Project:
www.wood-works.org